

2010

pamarpiū

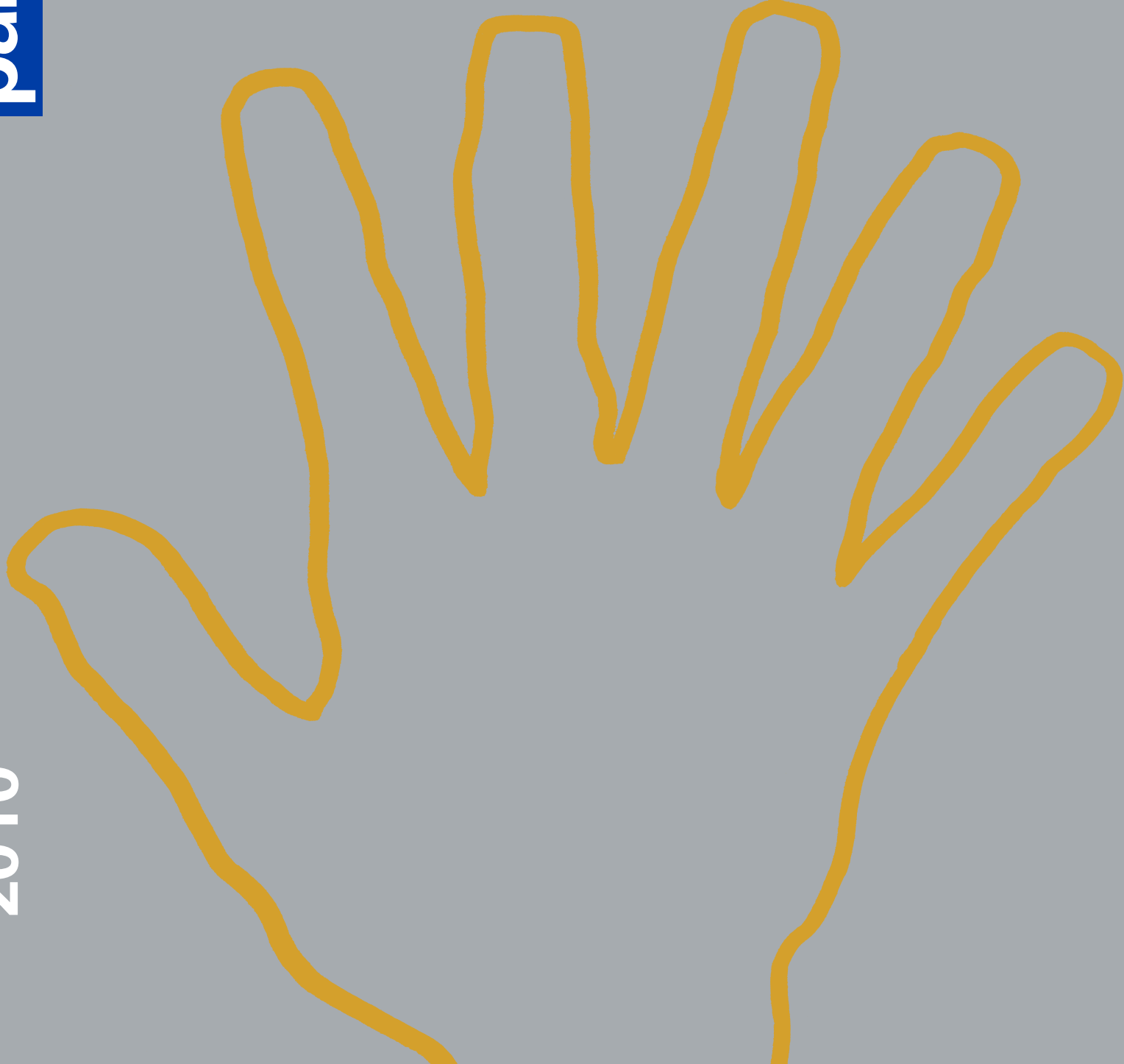

# pamarpiù

handles with care

indice / index

<b>autore</b>	<b>2</b>
<b>basic</b>	<b>20</b>
<b>extra</b>	<b>70</b>
passpartout_passacavi	74
slide_maniglie porte scorrevoli	80
wall_reggimensole	84
floor_piedini	86
hang 01_appendiabiti	88
hang 02_tubi e grucce	92

## Una storia tra le mani

E' agli inizi degli anni '50 che nasce Pamar, una delle numerose e straordinarie realtà lombarde scaturite dalla grande voglia di fare di molti imprenditori di allora, dal loro desiderio di mettersi alla prova, dal coraggio di rischiare. Storia di uomini dunque, tenaci e intraprendenti, come Angelo Redaelli che, dopo aver diretto nel primo dopoguerra uno stabilimento di torcitura, si sente pronto per dar vita ad una sua impresa.

E' il mondo della componentistica e della minuteria metallica che lo attrae, incoraggiato dalla madre e sostenuto nel suo progetto dalla moglie, che da subito partecipa attivamente, diventando una figura insostituibile, per il suo dinamismo e spirito organizzativo.

Pamar, azienda specializzata nella produzione di maniglie, pomoli e accessori per mobili, si sviluppa con rapidità, assumendo via via la struttura definita e l'assetto di una vera industria, puntando ininterrottamente alla qualità, all'innovazione e all'efficienza.

E il successo non si fa attendere. Le maniglie di Pamar vengono sempre più richieste, affiancando e supportando con efficacia la crescita del mobile italiano e la sua diffusione nel mondo. Dalla metà degli anni ottanta l'espansione aziendale procede a livello internazionale, sia grazie all'apporto professionale dei figli, Marco, Fabio e Silvia, che collaborano con passione ed entusiasmo, ognuno con competenze specifiche, sia per la partecipazione a progetti e mostre in tutto il mondo. Le capacità organizzative e produttive di Pamar, la sua costante volontà di crescita la trasformano da semplice produttore di oggetti a partner affidabile delle più importanti aziende mobiliere su scala mondiale, offrendo loro progetti ad hoc e prodotti esclusivi: un vero servizio su misura, seguito con attenzione e competenza dallo sviluppo dell'idea alla sua ingegnerizzazione e realizzazione.

## A story in hand

As with many other exceptional companies based within the Lombardy region, Pamar was founded in the early fifties during a time when many entrepreneurs took initiative based on their desire to put themselves to the test and their courage to take risks. It's the story of determined, enterprising people such as Angelo Redaelli, who felt ready to set up his own company after managing a small metalworking company in the immediate post-war years. Attracted by the world of small metal components and accessories, Mr Redaelli was encouraged by his mother and supported by his wife who played an important and active role right from the start, thereafter becoming an essential member of the team, thanks to her dynamism and organisational abilities. Pamar specialized in the production of handles, knobs and furniture accessories, developing quickly and progressively into an industrial structure, whose objectives at all times were quality, innovation and efficiency.

Success didn't take long in coming. The demand for Pamar handles grew as the Italian furniture sector became stronger, hence increasingly expanding its market internationally.

From the mid-eighties, the company constant growth was partly thanks to the assiduous contribution of the founder's children, Marco, Fabio and Silvia, who worked with passion and enthusiasm each with their own specific skills, and partly through the company's participation in projects and trade fair events all over the world. Pamar's organisational and production capacities and its determination towards growth have transformed it from a simple manufacturer of objects into a reliable partner for important furniture companies worldwide, to which it offers customised designs and exclusive products; a truly made to measure service, followed by care and skill from the starting development of the idea to its engineering and transformation into concrete end reality.





**autore**

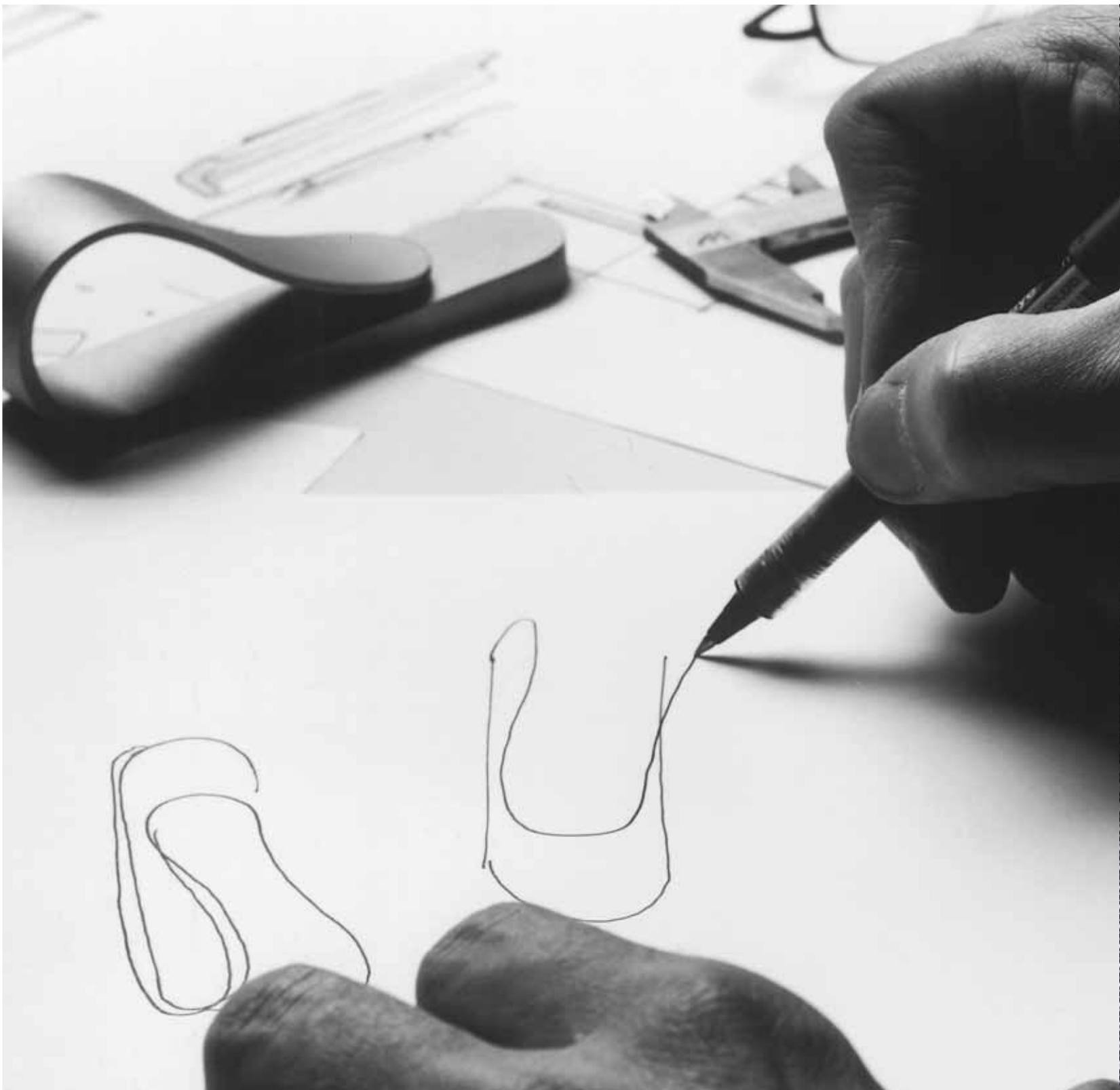

The designers





Rodolfo Dordoni

Björn Dahlstrom

James Irvine

Jasper Morrison

**SOLID** design Björn Dahlstrom

codice / code MN1176Z

finiture / finishings GC011  
cromato lucido / bright chromium plated

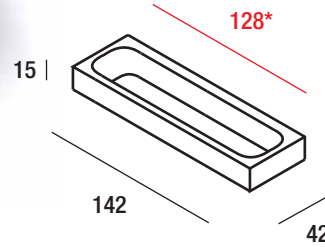

**SOLID** design Björn Dahlstrom

codice / code MN1176L

finiture / finishings LN027  
legno noce canaletto / canaletto walnut wood

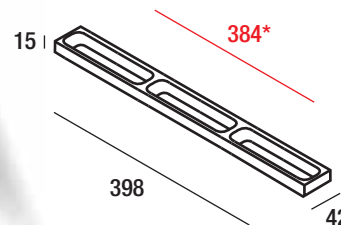
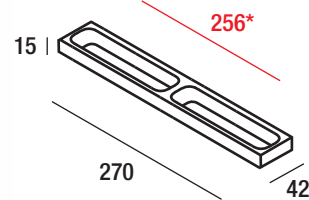
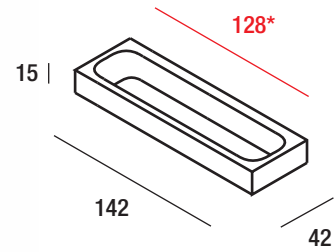



## SLICE design Björn Dahlstrom

codice / code MN1177Z

finiture / finishings  
EZ004  
metallizzato zinco opaco / mat metallized zinc  
GC011  
cromato lucido / bright chromium plated

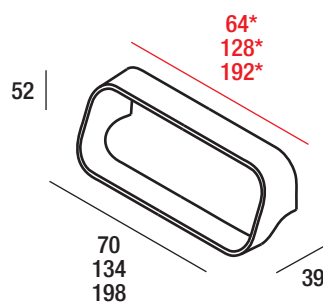

## EDGE design Björn Dahlstrom

codice / code MN1174Z

finiture / finishings  
EZ004  
metallizzato zinco opaco / mat metallized zinc  
GC011  
cromato lucido / bright chromium plated

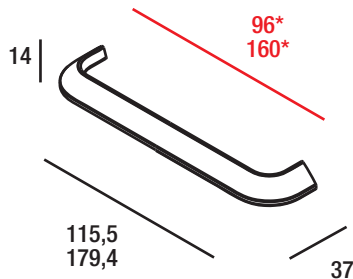



## WING design Björn Dahlstrom

**codice / code** MN1175Z

**finiture / finishings** EA005  
metallizzato alluminio opaco / mat metallized aluminium  
GC011  
cromato lucido / bright chromium plated

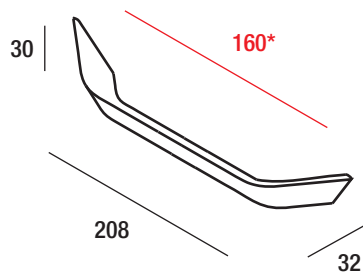

## HOLE design James Irvine

**codice / code** MN1186Z

**finiture / finishings** GC011  
cromato lucido / bright chromium plated  
GC013  
cromo mat / mat chrome

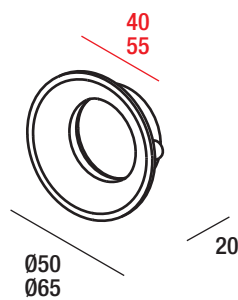

**HOLE** design James Irvine

**codice / code** MN1185Z

**finiture / finishings** GC011  
cromato lucido / bright chromium plated  
GC013  
cromo mat / mat chrome

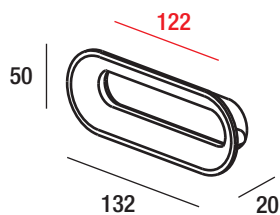

**HOLE** design James Irvine

**codice / code** MN1187Z

**finiture / finishings** GC011  
cromato lucido / bright chromium plated  
GC013  
cromo mat / mat chrome

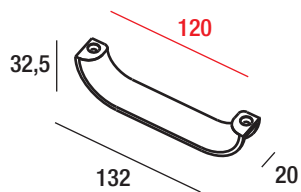

## SMOOTH design James Irvine

**codice / code** MN1117Z

**finiture / finishings** E2002  
metallizzato zinco opaco con fondo /  
mat metallized zinc with primer  
E228  
nero opaco con fondo / mat black with primer

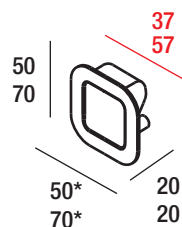

## SMOOTH design James Irvine

**codice / code** MN1116Z

**finiture / finishings** E215  
metallizzato alluminio opaco con fondo /  
mat metallized aluminium with primer  
E229  
bianco opaco con fondo / mat white with primer  
G171  
nichel mat satinato / satin mat nickel

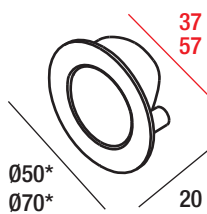

## SMOOTH design James Irvine

**codice / code** MN1115Z

**finiture / finishings** E2002  
metallizzato zinco opaco con fondo /  
mat metallized zinc with primer  
E228  
nero opaco con fondo / mat black with primer

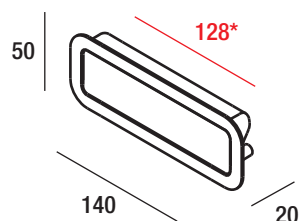

## SMOOTH design James Irvine

**codice / code** MN1114Z

**finiture / finishings** E215  
metallizzato alluminio opaco con fondo /  
mat metallized aluminium with primer  
E229  
bianco opaco con fondo / mat white with primer  
G171  
nichel mat satinato / satin mat nickel

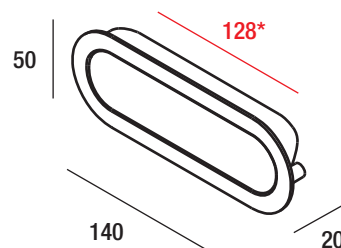

## BUTTON design James Irvine

**codice / code** MN1180Z

**finiture / finishings** GC011  
cromato lucido / bright chromium plated  
GN020  
nichel lucido satinato con vernice trasparente /  
bright satin nickel with bright paint

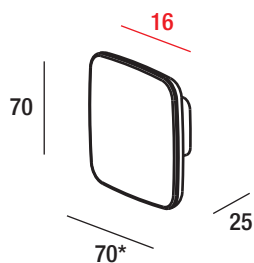

## BUTTON design James Irvine

**codice / code** MN1181Z

**finiture / finishings** GC011  
cromato lucido / bright chromium plated  
GN020  
nichel lucido satinato con vernice trasparente /  
bright satin nickel with bright paint

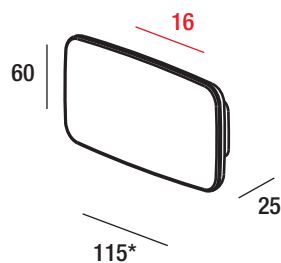



## BUTTON design James Irvine

**codice / code** MN1179Z

**finiture / finishings** GC011  
cromato lucido / bright chromium plated  
GN020  
nichel lucido satinato con vernice trasparente /  
bright satin nickel with bright paint

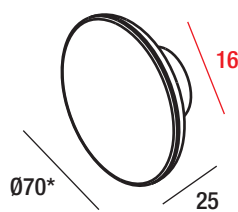

## CORK design Jasper Morrison

**codice / code** PO2012S

**finiture / finishings** TS018  
sughero / cork

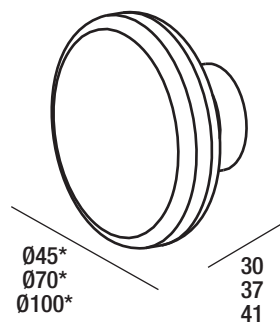

## SOFT design Rodolfo Dordoni

codice / code MN1190Z

finiture / finishings GC011  
cromato lucido / bright chromium plated

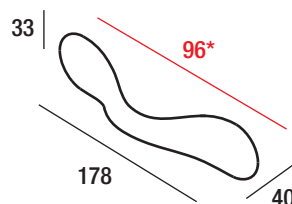

## MURANO design Rodolfo Dordoni

codice / code MN1122V

finiture / finishings Y1374  
vetro ambra + cromato lucido /  
ambra glass + bright chromium plated  
Y1375  
vetro fumè + cromato lucido /  
fumè glass + bright chromium plated

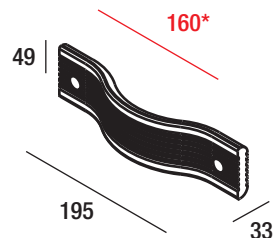

## TWIST design Rodolfo Dordoni

codice / code MN1121Z

finiture / finishings  
G104  
cromato lucido / bright chromium plated  
G171  
nichel mat satinato / satin mat nickel

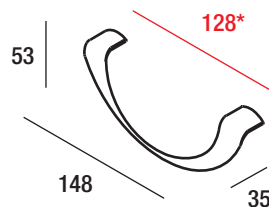

## FOLD design Rodolfo Dordoni

codice / code MN1191Z

finiture / finishings  
G104  
cromato lucido / bright chromium plated  
G124  
nichel lucido satinato con vernice trasparente /  
bright satin nickel with bright paint

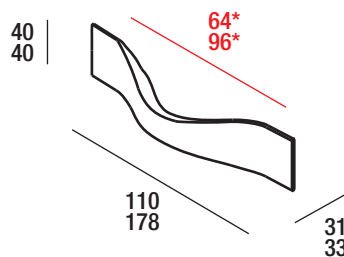

## BEND design Rodolfo Dordoni

**codice / code** MN1189Z

**finiture / finishings** GC011  
cromato lucido / bright chromium plated

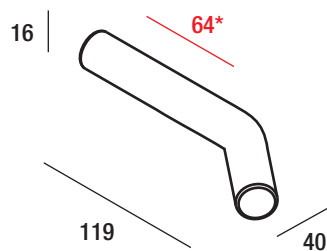

## CLIP design Rodolfo Dordoni

**codice / code** MN1112Z

**finiture / finishings** EZ002  
metallizzato zinco opaco con fondo /  
mat metallized zinc with primer  
G104  
cromato lucido / bright chromium plated

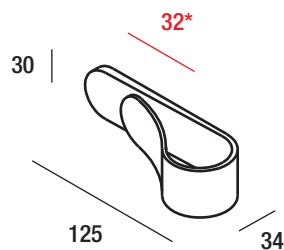

**DALI'** design Rodolfo Dordoni

**codice / code** MN1120Z

**finiture / finishings** E194  
metallizzato ferro vecchio lucido /  
bright metallized old iron  
G104  
cromato lucido / bright chromium plated

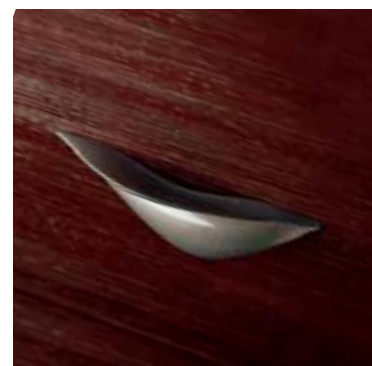
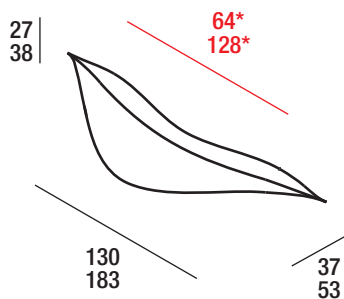

**TAKE** design Rodolfo Dordoni

**codice / code** MN1113Z

**finiture / finishings** E101  
metallizzato alluminio opaco /  
mat metallized aluminium  
G104  
cromato lucido / bright chromium plated  
G171  
nichel mat satinato / satin mat nickel

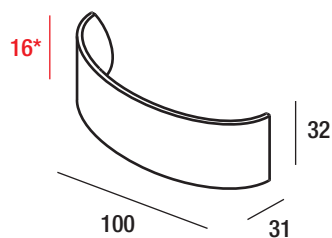



## HOOP design Rodolfo Dordoni

codice / code MN1109Z

finiture / finishings  
G104  
cromato lucido / bright chromium plated  
G171  
nichel mat satinato / satin mat nickel

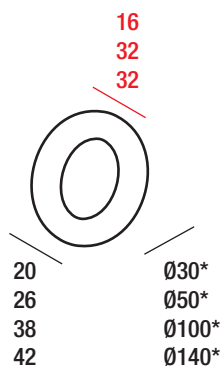

## T. BONE design Rodolfo Dordoni

codice / code MN1110L

finiture / finishings  
L106  
legno noce canaletto / canaletto walnut wood  
W0431  
legno rovere moro / dark oak wood

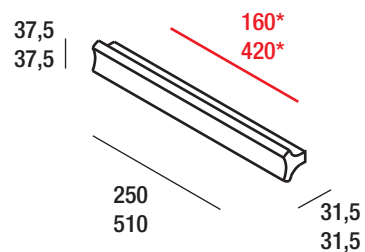



# basic





## Il design, un valore

Per chi, come Pamar, ha fatto della ricerca e della sperimentazione un tratto caratteristico della sua storia, è stato altrettanto naturale considerare il design un elemento fondamentale di distinzione e di costruzione della propria identità.

E' dagli anni novanta che l'azienda comincia a lavorare a stretto contatto con numerosi architetti e designers, con personalità progettuali e linguaggi espressivi diversi.

Grazie a loro, Pamar studia e sperimenta sempre nuove forme, applica nuovi materiali e nuove finiture costruendo una collezione fortemente caratterizzata: una selezione di oltre quattrocento diverse tipologie di maniglie, a ponte, barra, incasso, pomoli e ciondoli, interpretate con estetiche molteplici e con una grande varietà di finiture, capaci di rispondere in modo diversificato e innovativo alle esigenze e ai desideri della propria clientela.

Pamar oggi conosce a fondo il mondo dell'arredamento a livello internazionale: sa cogliere, anticipare e soddisfare i bisogni sfaccettati dei protagonisti di questo settore.

Per questo può proporsi non solo come semplice fornitore di componenti ma come vero e proprio partner per le aziende produttrici di mobili di design. A queste Pamar è in grado di offrire prodotti a forte contenuto progettuale, dal design ricercato e inconfondibile, realizzati interamente in Italia e garantiti integralmente. Per Pamar il design non è un semplice attributo, è il valore che esprime e sottolinea la sua realtà.

## Design as a core value

For a company like Pamar, which has made research and experimentation a way of life,

it comes naturally to consider design a fundamental element whereby it differentiates itself and affirms its own identity.

Since the nineties, the company has worked closely with numerous architects and designers, each of whom represents a different professional personality and form of artistic expression.

Thanks to them, Pamar is constantly studying and experimenting with new shapes, making use of new materials and new finishes, to build up a very distinctive collection: a selection of over 400 different types of handles, bridge, bar and recessed handles, knobs and pendants, interpreted in multiple aesthetic styles and with a wide variety of finishes. These products meet the requirements and desires of customers in diverse, innovative ways. Pamar has a profound knowledge of the furniture market internationally:

it understands, foresees and satisfies the multi-faceted needs of the leaders in this sector. For this reason, it may be seen not only as simply a supplier of components but as a true partner for manufacturers of designer furniture. Pamar offers them products with a strong design component, products of refined and unmistakable design, entirely Italian-made and fully guaranteed.

For Pamar, design is not just a simple attribute, it is a value which expresses and underpins its existence.



## The designers



Gordon Guillaumier

Lino Codato

Alessandro Piva

Pinuccio Borgonovo

Marco Zanuso Jr.

Sung Sook Kim







Giuseppe Bavuso

Fabio Redaelli

Silvano Barsacchi

Alessandro Elli

Gian Vittorio Plazzogna

Klaus Bergen



## MN1087Z design Marco Zanuso Jr.

**codice / code** MN1087Z

**finiture / finishings**  
G104  
cromato lucido / bright chromium plated  
G124  
nichel lucido satinato con vernice trasparente /  
bright satin nickel with bright paint  
G172  
cromo mat / mat chrome

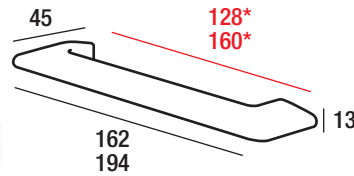

## MN1145Z design Gordon Guillaumier

**codice / code** MN1145Z

**finiture / finishings**  
G104  
cromato lucido / bright chromium plated  
G115  
nichel lucido satinato / bright satin nickel

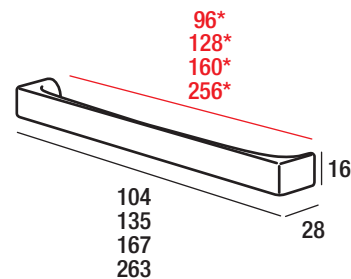

## MN1088Z design Marco Zanuso Jr.

**codice / code** MN1088Z

**finiture / finishings** G104  
cromato lucido / bright chromium plated  
G115  
nichel lucido satinato / bright satin nickel

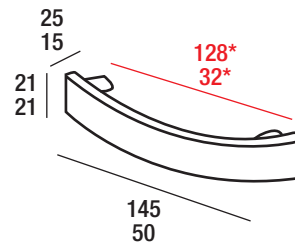

## MN735Z design Marelli e Molteni

**codice / code** MN735Z

**finiture / finishings** E101  
metallizzato alluminio opaco / mat metallized aluminium  
G104  
cromato lucido / bright chromium plated  
G115  
nichel lucido satinato / bright satin nickel

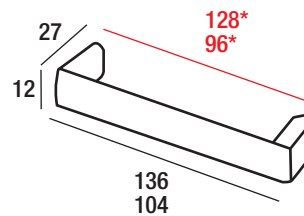



**MN2133Z** design Gordon Guillaumier

**codice / code** MN2133Z

**finiture / finishings** G104  
cromato lucido / bright chromium plated

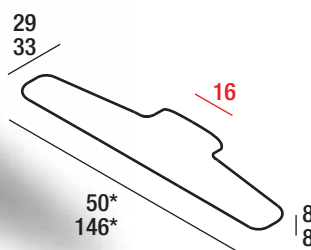

**MN934Z** design CRP

**codice / code** MN934Z

**finiture / finishings** G104  
cromato lucido / bright chromium plated

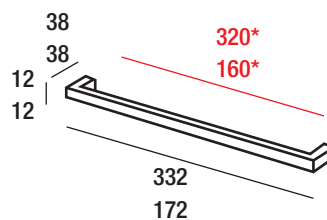

**MN2102Z** design Gordon Guillaumier

**codice / code** MN2102Z  
**finiture / finishings** G104  
cromato lucido / bright chromium plated

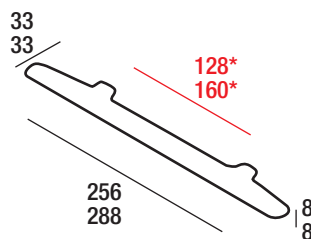

**MN935Z** design CRP

**codice / code** MN935Z  
**finiture / finishings** G104  
cromato lucido / bright chromium plated

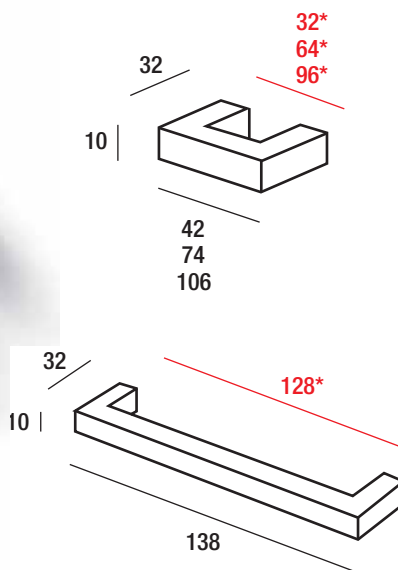

## MN804Z design CRP

codice / code MN804Z

finiture / finishings G115  
nichel lucido satinato / bright satin nickel

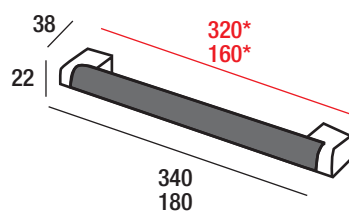

## PO4560 design Gordon Guillaumier

codice / code PO4560

finiture / finishings G104L110  
cromato lucido + legno rovere panga /  
bright chromium plated + oak panga wood

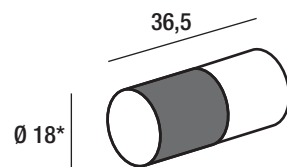



**MN1044Z** design Gordon Guillaumier

**codice / code** MN1044Z

**finiture / finishings** G104L110  
cromato lucido + legno rovere panga /  
bright chromium plated + oak panga wood

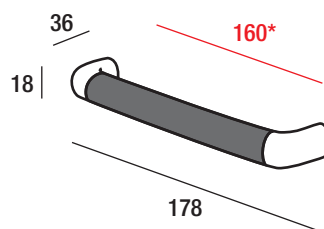

**PO454Z** design Gordon Guillaumier

**codice / code** PO454Z

**finiture / finishings** G104L110  
cromato lucido + legno rovere panga /  
bright chromium plated + oak panga wood

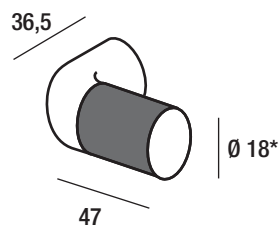

## PO313Z design Marelli e Molteni

**codice / code** PO313Z

**finiture / finishings** E101  
metallizzato alluminio opaco / mat metallized aluminium  
G104  
cromato lucido / bright chromium plated  
G124  
nichel lucido satinato con vernice trasparente /  
bright satin nickel with bright paint

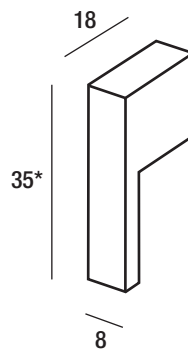

## PO433Z design Marelli e Molteni

**codice / code** PO433Z

**finiture / finishings** E101  
metallizzato alluminio opaco / mat metallized aluminium  
G104  
cromato lucido / bright chromium plated

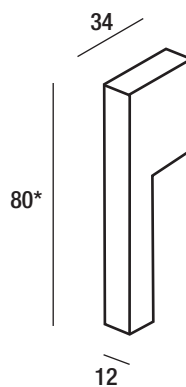

## MN940Z design Marelli e Molteni

**codice / code** MN940Z

**finiture / finishings** E215  
metallizzato alluminio opaco con fondo /  
mat metallized aluminium with primer  
G104  
cromato lucido / bright chromium plated

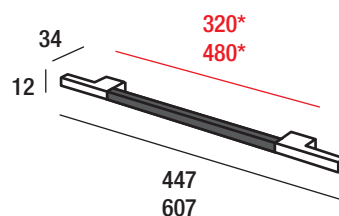

## MN882Z design CRP

**codice / code** MN882Z

**finiture / finishings** E101  
metallizzato alluminio opaco / mat metallized aluminium  
G104  
cromato lucido / bright chromium plated  
G115  
nichel lucido satinato / bright satin nickel

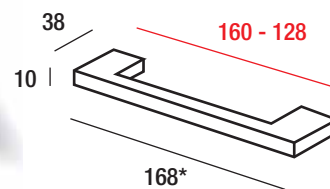

## MN707Z design Fabio Redaelli

**codice / code** MN707Z

**finiture / finishings** E101  
metallizzato alluminio opaco / mat metallized aluminium  
G171  
nichel mat satinato / satin mat nickel

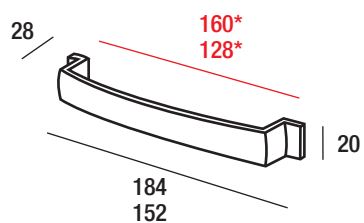

## MN496Z design CRP

**codice / code** MN496Z

**finiture / finishings** E101  
metallizzato alluminio opaco / mat metallized aluminium  
G104  
cromato lucido / bright chromium plated  
G115  
nichel lucido satinato / bright satin nickel

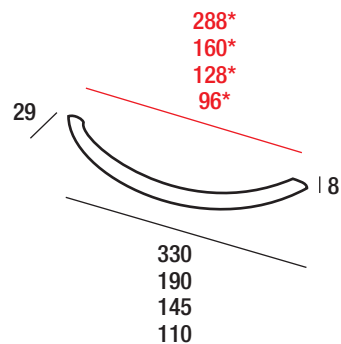

## MN836-1A design Fabio Redaelli

codice / code MN836-1A

finiture / finishings  
A190  
surlyn trasparente texture / surlyn transparent texture  
A217  
surlyn trasparente grigio fumè texture /  
surlyn transparent texture grey fumè

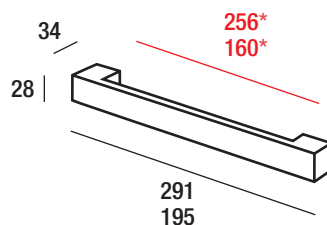

## MN644Z design Fabio Redaelli

codice / code MN644Z

finiture / finishings  
E103  
metallizzato argento mat / mat metallized silver  
G104  
cromato lucido / bright chromium plated  
G107  
ottonato lucido / bright brass plated  
G110  
bronzo graffiato lucido / bright scratched bronze  
G115  
nichel lucido satinato / bright satin nickel  
G140  
bagno oro 24 kt / gold plated 24 kT

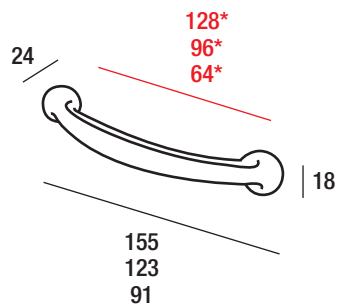

**PO464Z** design Gordon Guillaumier

**codice / code** PO464Z

**finiture / finishings** G115  
nichel lucido satinato / bright satin nickel  
GR024  
rame bronzo graffiato perlato /  
pearled scratched bronze copper

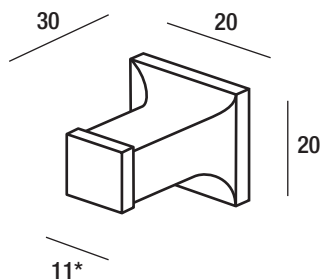

**PO467Z** design Sung Sook Kim

**codice / code** PO467Z

**finiture / finishings** GC011  
cromato lucido / bright chromium plated

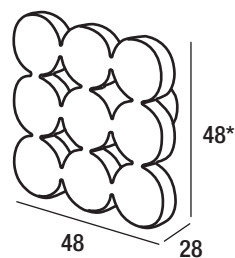
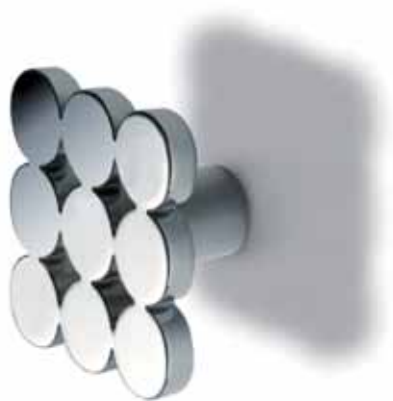



**MN1071Z** design Gordon Guillaumier

**codice / code** MN1071Z

**finiture / finishings** G115  
nichel lucido satinato / bright satin nickel  
GR024  
rame bronzo graffiato perlato /  
pearled scratched bronze copper

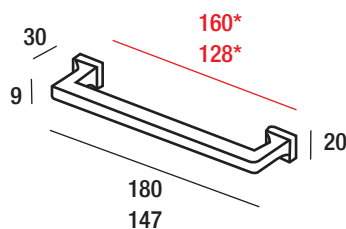

**MN1086Z** design Sung Sook Kim

**codice / code** MN1086Z

**finiture / finishings** GC011  
cromato lucido / bright chromium plated

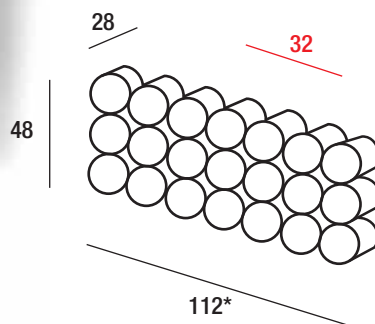

**PO20100** design Sung Sook Kim

**codice / code** PO20100

**finiture / finishings** Y0672  
cromato lucido + cristallo trasparente /  
bright chromium plated + transparent crystal  
Y1098  
bagno oro 24 kt + cristallo trasparente /  
gold plated 24 kt + transparent crystal

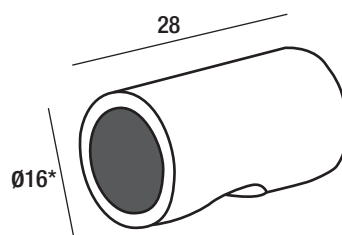

**PO2008Z** design Sung Sook Kim

**codice / code** PO2008Z

**finiture / finishings** Y0672  
cromato lucido + cristallo trasparente /  
bright chromium plated + transparent crystal  
Y1098  
bagno oro 24 kt + cristallo trasparente /  
gold plated 24 kt + transparent crystal

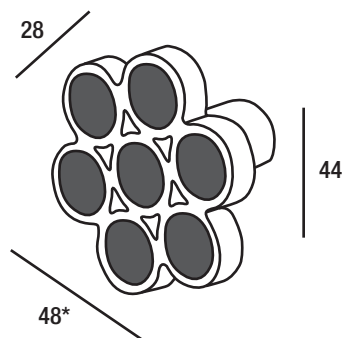

## MN2091Z design Sung Sook Kim

codice / code MN2091Z

finiture / finishings  
Y0672  
cromato lucido + cristallo trasparente /  
bright chromium plated + transparent crystal  
Y1098  
bagno oro 24 kt + cristallo trasparente /  
gold plated 24 kt + transparent crystal

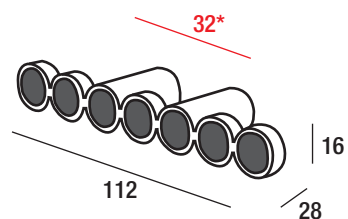

## MN2078Z design Sung Sook Kim

codice / code MN2078Z

finiture / finishings  
Y0672  
cromato lucido + cristallo trasparente /  
bright chromium plated + transparent crystal  
Y1098  
bagno oro 24 kt + cristallo trasparente /  
gold plated 24 kt + transparent crystal

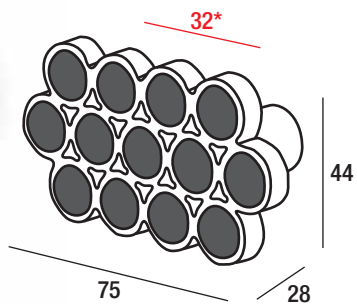

## MN400Z design CRP

**codice / code** MN400Z

**finiture / finishings**

E101U119  
metallizzato alluminio opaco + cuoio naturale /  
mat metallized aluminium + natural stronger  
leather twist  
E101U121  
metallizzato alluminio opaco + cuoio marrone /  
mat metallized aluminium + brown stronger  
leather twist  
G104U119  
cromato lucido + cuoio naturale /  
bright chromium plated + natural stronger leather twist  
G104U121  
cromato lucido + cuoio marrone /  
bright chromium plated + brown stronger leather twist

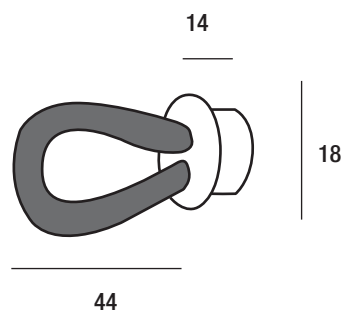

## MN569U design CRP

**codice / code** MN569U

**finiture / finishings**

U119E101  
metallizzato alluminio opaco + cuoio naturale /  
mat metallized aluminium + natural stronger  
leather twist  
U119G104  
cromato lucido + cuoio naturale /  
bright chromium plated + natural stronger leather twist  
U121E101  
metallizzato alluminio opaco + cuoio marrone /  
mat metallized aluminium + brown stronger  
leather twist  
U121G104  
cromato lucido + cuoio marrone /  
bright chromium plated + brown stronger leather twist

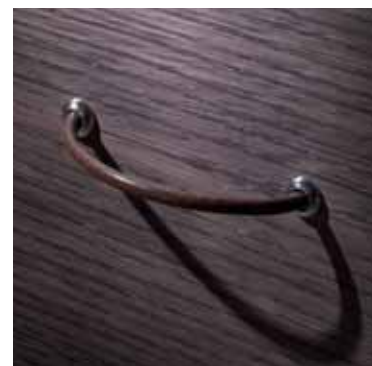
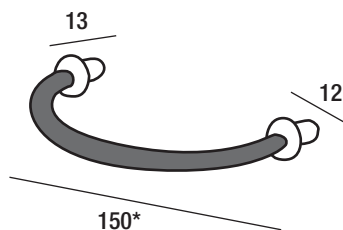





## MN1060Z design Gordon Guillaumier



**codice / code** MN1060Z  
**finiture / finishings** EZ004  
metallizzato zinco opaco / mat metallized zinc  
G104  
cromato lucido / bright chromium plated  
G124  
nichel lucido satinato con vernice trasparente /  
bright satin nickel with bright paint

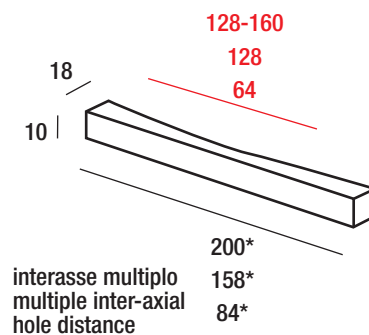

## PO459Z design Gordon Guillaumier



**codice / code** PO459Z  
**finiture / finishings** E101  
metallizzato alluminio opaco / mat metallized aluminium  
G104  
cromato lucido / bright chromium plated  
G124  
nichel lucido satinato con vernice trasparente /  
bright satin nickel with bright paint

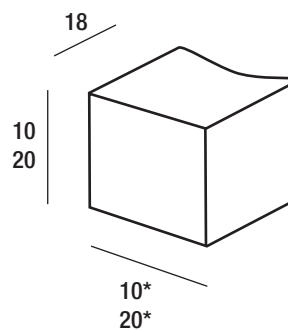



**MN1046Z** design Gordon Guillaumier



**codice / code** MN1046Z  
**finiture / finishings** E101  
 metallizzato alluminio opaco / mat metallized aluminium G104  
 cromato lucido / bright chromium plated G124  
 nichel lucido satinato con vernice trasparente / bright satin nickel with bright paint

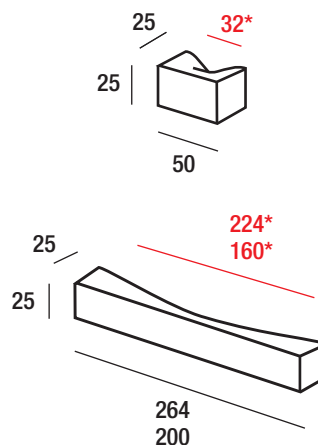

**MN2103Z** design Gordon Guillaumier



**codice / code** MN2103Z  
**finiture / finishings** G104  
 cromato lucido / bright chromium plated

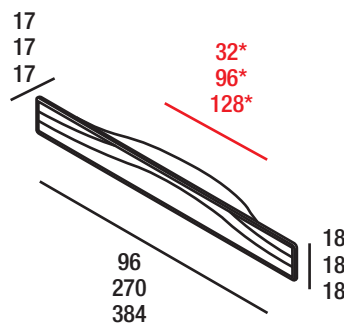

## PO319Z design Marelli e Molteni

codice / code PO319Z

finiture / finishings E101  
metallizzato alluminio opaco / mat metallized aluminium G104  
cromato lucido / bright chromium plated G124  
nichel lucido satinato con vernice trasparente / bright satin nickel with bright paint

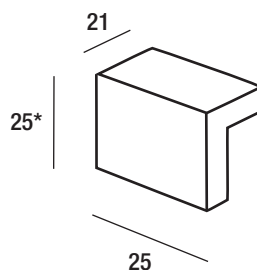

## MN886Z design Giuseppe Bavuso

codice / code MN886Z

finiture / finishings E101  
metallizzato alluminio opaco / mat metallized aluminium G104  
cromato lucido / bright chromium plated G124  
nichel lucido satinato con vernice trasparente / bright satin nickel with bright paint

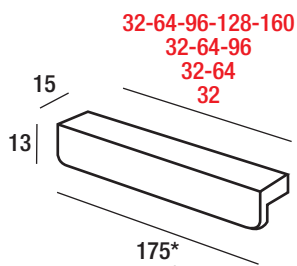
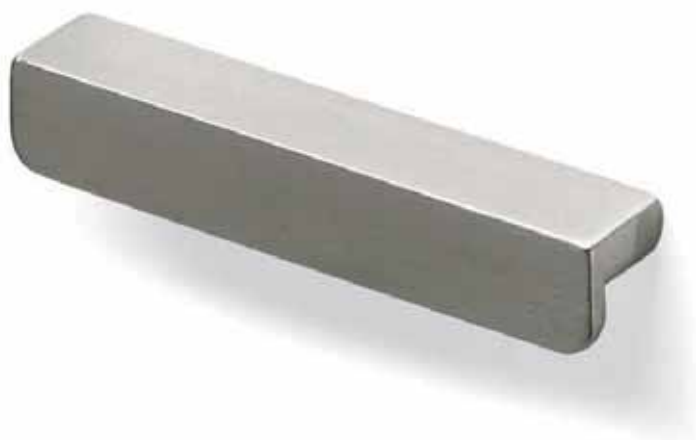

interasse multiplo  
multiple inter-axial  
hole distance

175\*  
110\*  
80\*  
45\*



**MN646Z** design Marelli e Molteni

**codice / code** MN646Z

**finiture / finishings** E101  
 metallizzato alluminio opaco / mat metallized aluminium G104  
 cromato lucido / bright chromium plated G124  
 nichel lucido satinato con vernice trasparente / bright satin nickel with bright paint

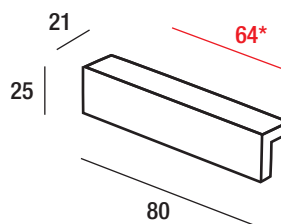

**MN1172Z** design Alessandro Elli

**codice / code** MN1172Z

**finiture / finishings** GC011  
 cromato lucido / bright chromium plated GN020  
 nichel lucido satinato con vernice trasparente / bright satin nickel with bright paint

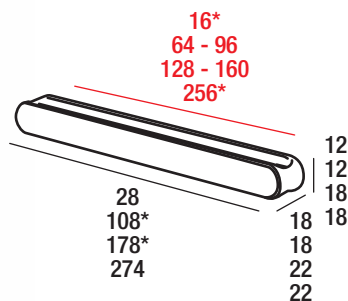

**interasse multiplo**  
**multiple inter-axial hole distance**



## MN695Z design Giuseppe Bavuso

codice / code MN695Z

finiture / finishings E101  
metallizzato alluminio opaco / mat metallized aluminium

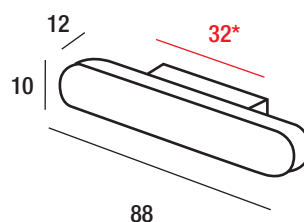

## MN751Z design Giuseppe Bavuso

codice / code MN751Z

finiture / finishings E101  
metallizzato alluminio opaco / mat metallized aluminium  
G104  
cromato lucido / bright chromium plated  
G115  
nichel lucido satinato / bright satin nickel

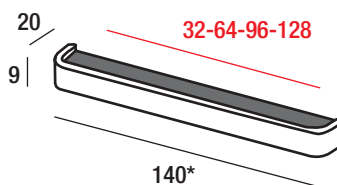
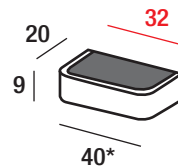
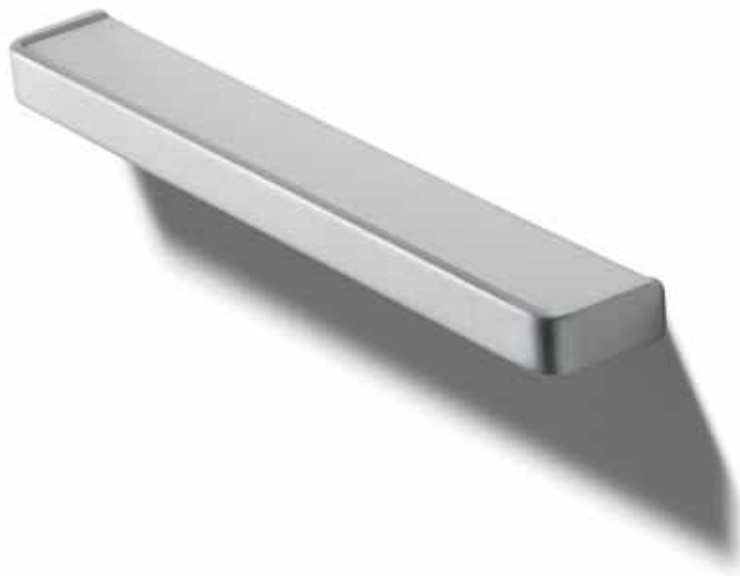

interasse multiplo / multiple Inter-axial  
hole distance



## MN971Z design Klaus Bergen

codice / code MN971Z

finiture / finishings E101  
metallizzato alluminio opaco / mat metallized aluminium

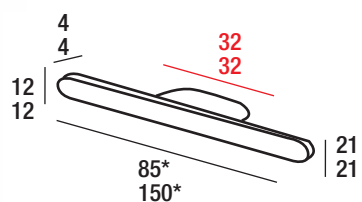

## MN769Z design Giuseppe Bavuso

codice / code MN769Z

finiture / finishings G115L110  
nichel lucido satinato + legno rovere panga /  
bright satin nickel + oak panga wood  
G115L111  
nichel lucido satinato + legno rovere sbiancato /  
bright satin nickel + bleached oak wood

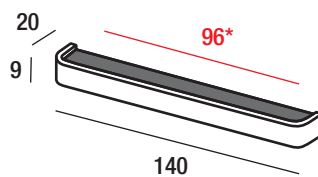
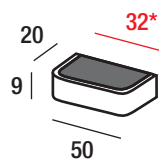



**PO475Z** design Gordon Guillaumier

**codice / code** PO475Z

**finiture / finishings** Y0734  
cromato lucido + cuoio testa di moro /  
bright chromium plated + dark brown stronger leather  
Y1381  
cromato lucido + simil legno rovere moro /  
bright chromium plated + dark oak simil wood

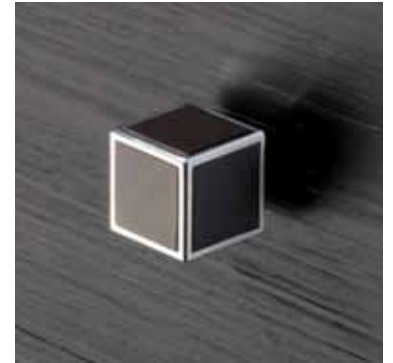
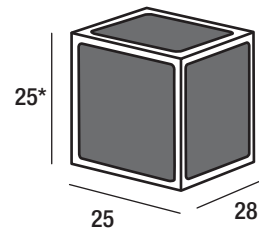

**MN2006** design Gordon Guillaumier

**codice / code** MN2006

**finiture / finishings** UA025  
cuoio avorio con bordo nero /  
ivory stronger leather with black border  
UT003  
cuoio testa di moro con bordo avorio /  
dark brown stronger leather with ivory border

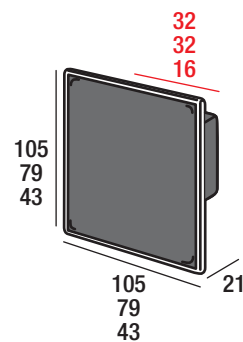

## MN1173Z design Gordon Guillaumier

codice / code MN1173Z

finiture / finishings Y0734  
cromato lucido + cuoio testa di moro /  
bright chromium plated + dark brown stronger leather  
Y1381  
cromato lucido + simil legno rovere moro /  
bright chromium plated + dark oak simil wood

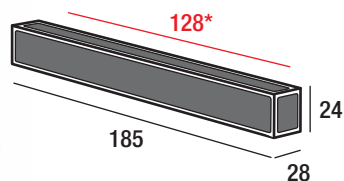

## MN2007 design Gordon Guillaumier

codice / code MN2007

finiture / finishings UA025  
cuoio avorio con bordo nero /  
ivory stronger leather with black border  
UT003  
cuoio testa di moro con bordo avorio /  
dark brown stronger leather with ivory border

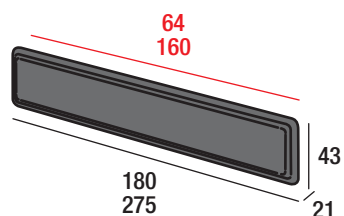
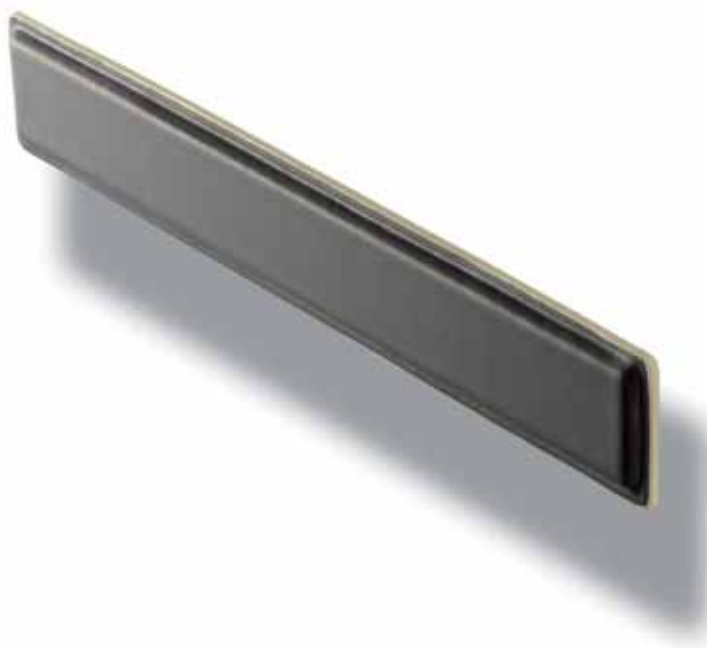

**MN2069Z** design Gordon Guillaumier

**codice / code** MN2069Z

**finiture / finishings** GC011  
cromato lucido / bright chromium plated  
GN020  
nichel lucido satinato con vernice trasparente /  
bright satin nickel with bright paint

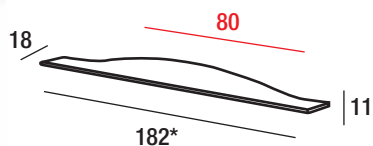

**MN2027V** design Gordon Guillaumier

**codice / code** MN2027V

**finiture / finishings** Y0557  
acciaio inox satinato + vetro trasparente extrachiaro /  
satin stainless steel + extralight transparent glass

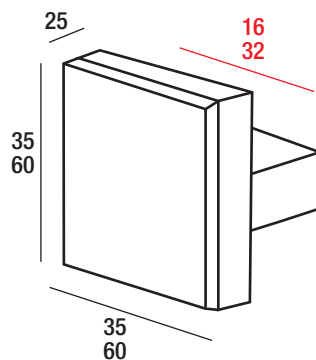

## MN2080Z design Gordon Guillaumier

**codice / code** MN2080Z

**finiture / finishings** GC011  
cromato lucido / bright chromium plated  
GN020  
nichel lucido satinato con vernice trasparente /  
bright satin nickel with bright paint



**foratura non in asse**    **holes not in axle**  
**interasse multiplo**    **multiple inter-axial**  
   **hole distance**

## MN2024V design Gordon Guillaumier

**codice / code** MN2024V

**finiture / finishings** Y0557  
acciaio inox satinato + vetro trasparente extrachiaro /  
satin stainless steel + extralight transparent glass

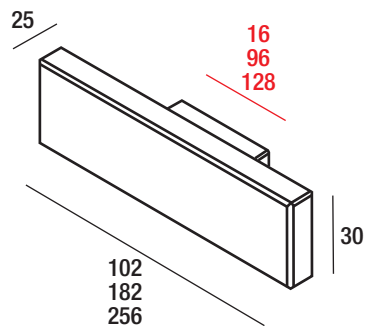

## MN1051Z design CRP

**codice / code** MN1051Z

**finiture / finishings** G115  
 nichel lucido satinato / bright satin nickel  
 G176  
 peltro satinato opaco / mat satin pewter

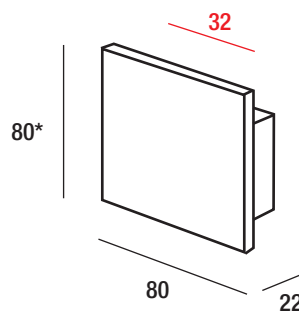

## MN868Z design Giuseppe Bavuso

**codice / code** MN868Z

**finiture / finishings** EZ004  
 metallizzato zinco opaco / mat metallized zinc  
 G115  
 nichel lucido satinato / bright satin nickel

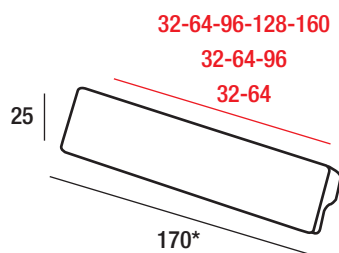
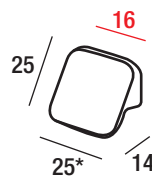

**interasse multiplo** 106\*  
**multiple inter-axial** 106\*  
**hole distance** 74\*





**MN958Z** design Giuseppe Bavuso

**codice / code** MN958Z

**finiture / finishings** G115  
 nichel lucido satinato / bright satin nickel  
 G176  
 peltro satinato opaco / mat satin pewter

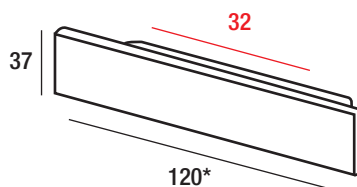

**MN2098Z** design Silvano Barsacchi

**codice / code** MN2098Z

**finiture / finishings** G104  
 cromato lucido / bright chromium plated

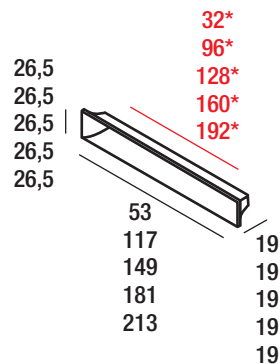

## MN2073G design Alessandro Elli

**codice / code** MN2073G

**finiture / finishings**  
OA011 gomma arancio / orange rubber  
OA069 gomma aragosta / lobster rubber  
OB055 gomma blu notte / night blue rubber  
OG006 gomma grigio / grey rubber  
OG024 gomma giallo cedro / citron yellow rubber  
OL009 gomma lavanda / lavender rubber  
OV029 gomma verde prato / grass green rubber

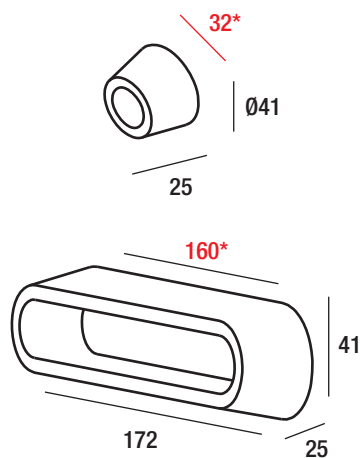

## MN2030Z design Alessandro Piva

**codice / code** MN2030Z

**finiture / finishings**  
GC011 cromato lucido / bright chromium plated  
GN020 nichel lucido satinato con vernice trasparente / bright satin nickel with bright paint

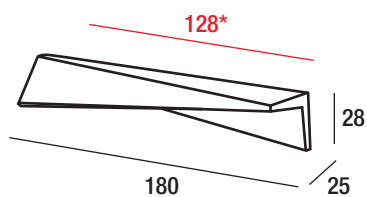

**MN2073Z** design Alessandro Elli

**codice / code** MN2073Z

**finiture / finishings** EA005  
metallizzato alluminio opaco / mat metallized aluminium

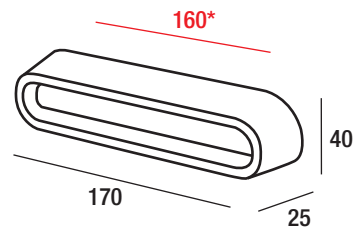
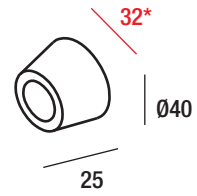

## MN1025Z design Pinuccio Borgonovo

codice / code MN1025Z

finiture / finishings E215  
metallizzato alluminio opaco con fondo /  
mat metallized aluminium with primer  
G115  
nichel lucido satinato / bright satin nickel

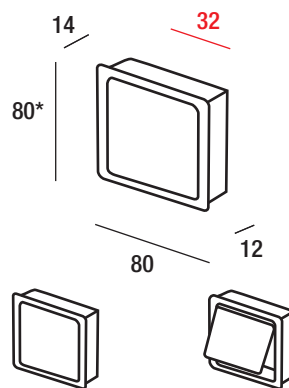

## MN1106Z design Pinuccio Borgonovo

codice / code MN1106Z

finiture / finishings E215  
metallizzato alluminio opaco con fondo /  
mat metallized aluminium with primer  
G115  
nichel lucido satinato / bright satin nickel

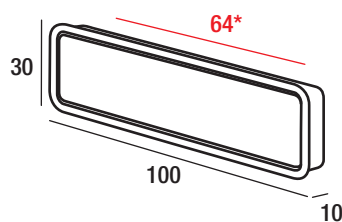

## MN1032Z design Pinuccio Borgonovo

codice / code MN1032Z

finiture / finishings E215  
metallizzato alluminio opaco con fondo /  
mat metallized aluminium with primer  
G115  
nichel lucido satinato / bright satin nickel

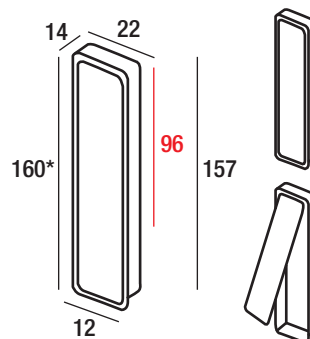

## MN959Z design Pinuccio Borgonovo

codice / code MN959Z

finiture / finishings E215  
metallizzato alluminio opaco con fondo /  
mat metallized aluminium with primer  
G115  
nichel lucido satinato / bright satin nickel

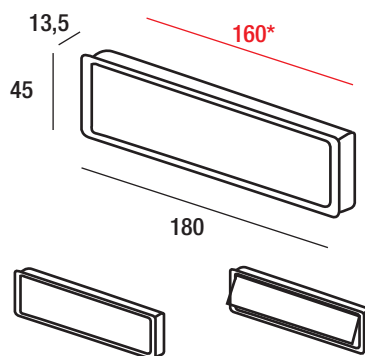



## MN880Z design Lino Codato

**codice / code** MN880Z

**finiture / finishings** G104  
cromato lucido / bright chromium plated  
G115  
nichel lucido satinato / bright satin nickel

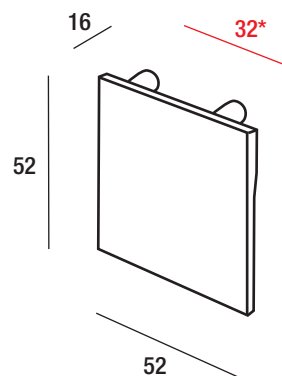

## MN747Z design Lino Codato

**codice / code** MN747Z

**finiture / finishings** G104  
cromato lucido / bright chromium plated  
G115  
nichel lucido satinato / bright satin nickel

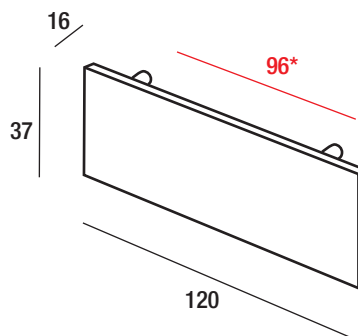

## CI189Z design Lino Codato

**codice / code** CI189Z

**finiture / finishings** G104  
cromato lucido / bright chromium plated  
G115  
nichel lucido satinato / bright satin nickel

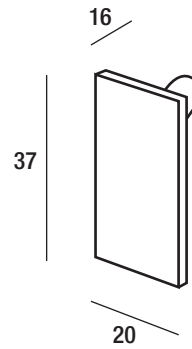

## MN743Z design CRP

**codice / code** MN743Z

**finiture / finishings** E101  
metallizzato alluminio opaco / mat metallized aluminium

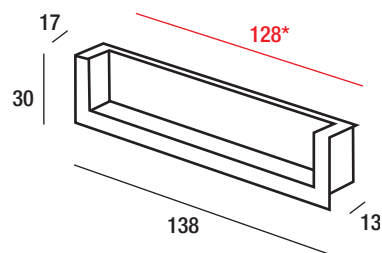

## MN503Z design CRP

codice / code MN503Z

finiture / finishings  
E101 metallizzato alluminio opaco / mat metallized aluminium  
G104 cromato lucido / bright chromium plated  
G115 nichel lucido satinato / bright satin nickel

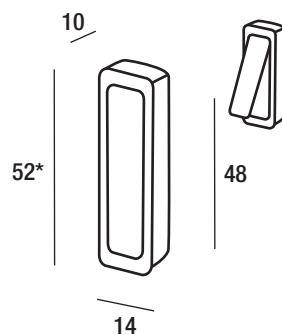

## MN689Z design Luigi Vaghi

codice / code MN689Z

finiture / finishings  
G171 nichel mat satinato / satin mat nickel

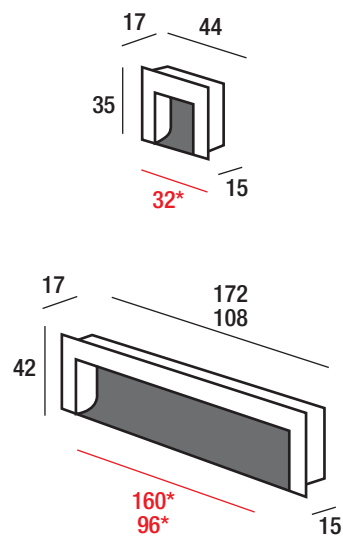

## MN295Z design CRP

**codice / code** MN295Z

**finiture / finishings** E101  
metallizzato alluminio opaco / mat metallized aluminium  
G104  
cromato lucido / bright chromium plated  
G115  
nichel lucido satinato / bright satin nickel

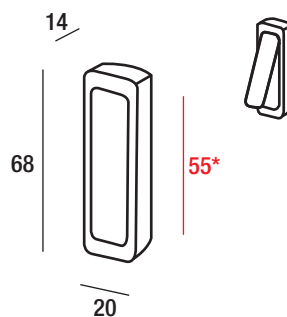

## MN926Z design CRP

**codice / code** MN926Z

**finiture / finishings** G171  
nichel mat satinato / satin mat nickel

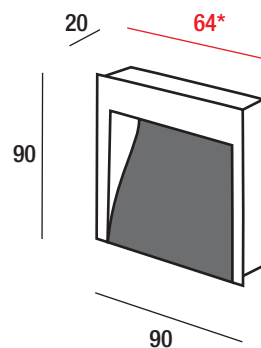

**MN2032Z** design Lino Codato

**codice / code** MN2032Z

**finiture / finishings** GC011  
cromato lucido / bright chromium plated  
GC013  
cromo mat / mat chrome

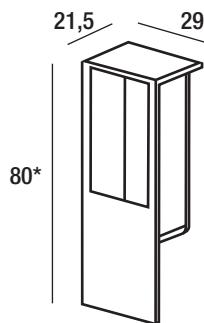

**MN1026Z** design Giuseppe Bavuso

**codice / code** MN1026Z

**finiture / finishings** EA004  
metallizzato alluminio opaco con fondo /  
mat metallized aluminium with primer  
GN019  
nichel lucido satinato / bright satin nickel

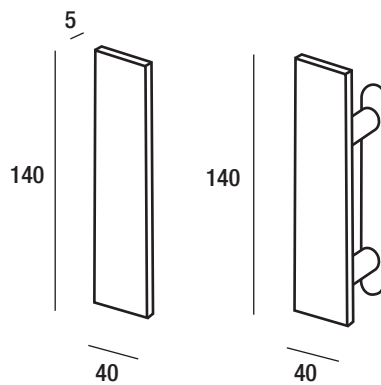



## MN800Z design Marelli e Molteni

codice / code MN800Z

finiture / finishings E101  
metallizzato alluminio opaco / mat metallized aluminium  
G104  
cromato lucido / bright chromium plated  
G171  
nichel mat satinato / satin mat nickel

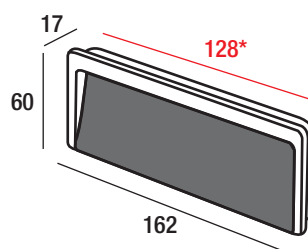
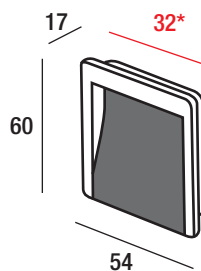

## MN1142Z design Gordon Guillaumier

codice / code MN1142Z

finiture / finishings GC011  
cromato lucido / bright chromium plated

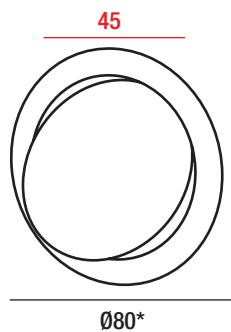

**PO2015Z** design CRP

**codice / code** PO2015Z

**finiture / finishings** E101  
metallizzato alluminio opaco / mat metallized aluminium G104  
cromato lucido / bright chromium plated

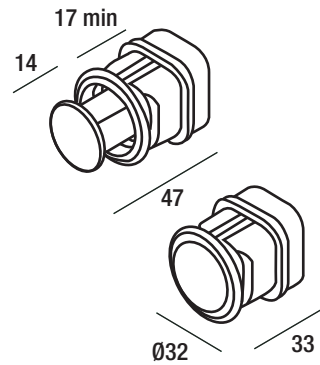

**PO450Z** design CRP

**codice / code** PO450Z

**finiture / finishings** EZ004  
metallizzato zinco opaco / mat metallized zinc

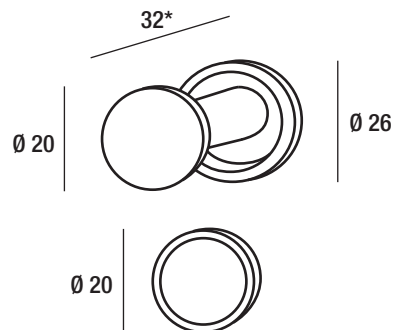

## PO2006Z design CRP

codice / code PO2006Z

finiture / finishings  
EZ004  
metallizzato zinco opaco / mat metallized zinc  
GC011  
cromato lucido / bright chromium plated

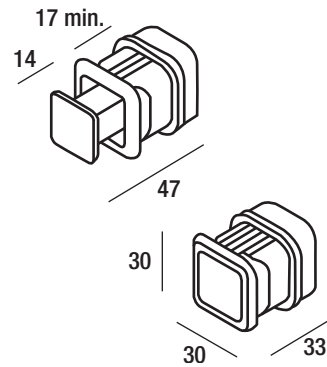

## MN1019Z design CRP

codice / code MN1019Z

finiture / finishings  
EZ002  
metallizzato zinco opaco con fondo /  
mat metallized zinc with primer

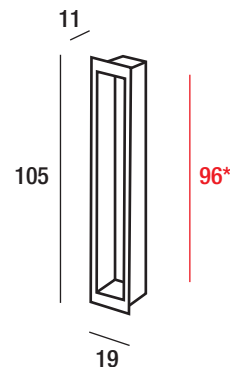

## MN2079Z design CRP

codice / code MN2079Z

finiture / finishings EA004  
metallizzato alluminio opaco con fondo /  
mat metallized aluminium with primer

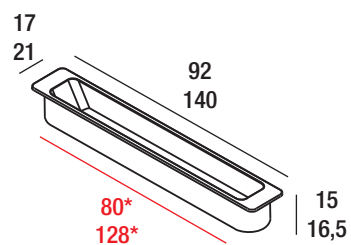

## MN2068Z design CRP

codice / code MN2068Z

finiture / finishings EZ004  
metallizzato zinco opaco / mat metallized zinc  
EN056  
nero acrilico lucido / bright acrylic black  
GC011  
cromato lucido / bright chromium plated

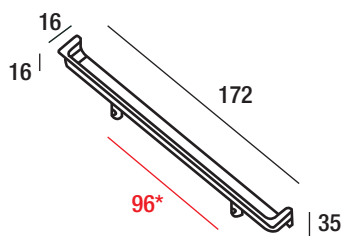



**PO2009C** design Gordon Guillaumier

**codice / code** PO2009C

**finiture / finishings**  
N101  
ceramica bianco lucido / bright white ceramics  
N102  
ceramica bianco opaco / mat white ceramics  
N103  
ceramica nero opaco / mat black ceramics  
N105  
ceramica nero lucido / bright black ceramics

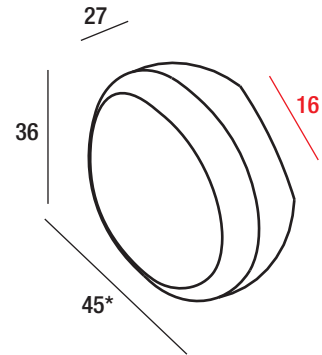

**PO289Z** design CRP

**codice / code** PO289Z

**finiture / finishings**  
G104  
cromato lucido / bright chromium plated  
G115  
nichel lucido satinato / bright satin nickel

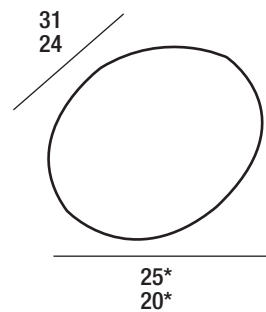



**MN2061C** design Gordon Guillaumier

**codice / code** MN2061C

**finiture / finishings** N101  
ceramica bianco lucido / bright white ceramics  
N102  
ceramica bianco opaco / mat white ceramics  
N103  
ceramica nero opaco / mat black ceramics  
N105  
ceramica nero lucido / bright black ceramics

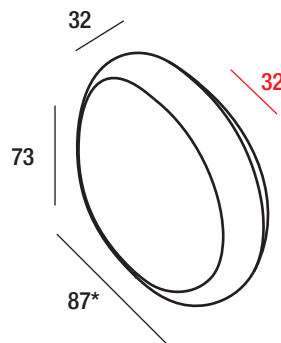

**PO324Z** design Marelli e Molteni

**codice / code** PO324Z

**finiture / finishings** E101  
metalizzato alluminio opaco / mat metallized aluminium  
G104  
cromato lucido / bright chromium plated  
G115  
nichel lucido satinato / bright satin nickel

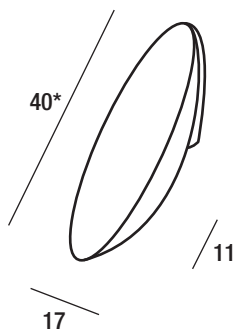

## MN2021Z design Silvano Barsacchi

**codice / code** MN2021Z

**finiture / finishings** GC011  
cromato lucido / bright chromium plated

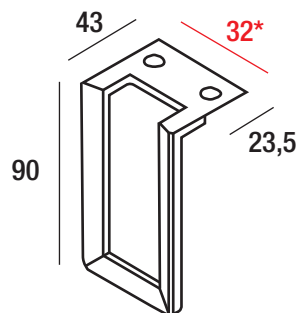

## MN2137G design Gian Vittorio Plazzogna

**codice / code** MN2137G

**finiture / finishings** O110  
gomma arancio albicocca / apricot orange rubber  
O117  
gomma blu notte / night blue rubber  
O120  
gomma verde prato / pray green rubber  
O121  
gomma lavanda / lavender rubber  
O124  
gomma trasparente arancio / transparent orange rubber  
O125  
gomma trasparente verde / transparent green rubber  
O126  
gomma trasparente azzurro / transparent light-blue rubber  
O127  
gomma trasparente viola / transparent purple rubber

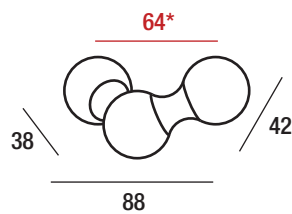
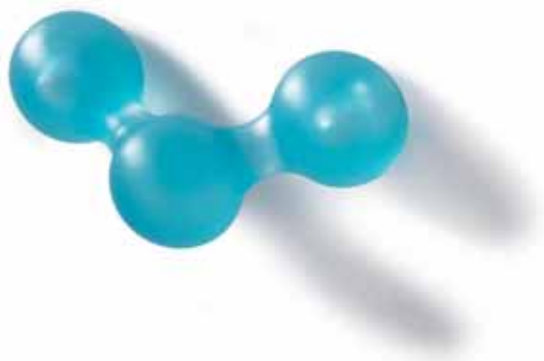

**PO336Z** design Giuseppe Bavuso

**codice / code** PO336Z

**finiture / finishings** E101  
metallizzato alluminio opaco / mat metallized aluminium  
G104  
cromato lucido / bright chromium plated  
G115  
nichel lucido satinato / bright satin nickel

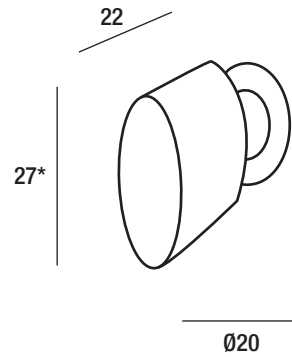



**extra**









passpartout\_passacavi

slide\_maniglie porte scorrevoli

wall\_reggimensole

floor\_piedini

hang 01\_appendiabiti

hang 02\_tubi e grucce



## PC2002Z design Giuseppe Bavuso

**codice / code** PC2002Z

**finiture / finishings** E215  
metallizzato alluminio opaco con fondo /  
mat metallized aluminium with primer  
G104  
cromato lucido / bright chromium plated

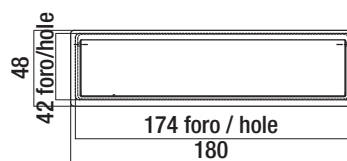

## PC2001Z150 design Giuseppe Bavuso

**codice / code** PC2001Z150

**finiture / finishings** E215  
metallizzato alluminio opaco con fondo /  
mat metallized aluminium with primer  
G104  
cromato lucido / bright chromium plated

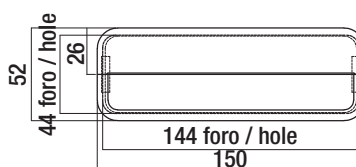

**PC2006Z** design Giuseppe Bavuso

**codice / code** PC2006Z

**finiture / finishings** E215  
metallizzato alluminio opaco con fondo /  
mat metallized aluminium with primer  
G104  
cromato lucido / bright chromium plated

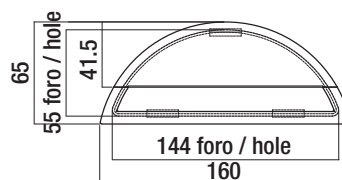

**PC2001Z76** design Giuseppe Bavuso

**codice / code** PC2001Z76

**finiture / finishings** E215  
metallizzato alluminio opaco con fondo /  
mat metallized aluminium with primer  
G104  
cromato lucido / bright chromium plated

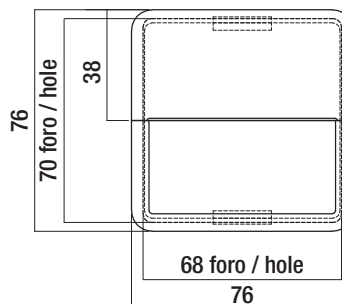

**PC2000Z78** design Giuseppe Bavuso

**codice / code** PC2000Z78

**finiture / finishings** EZ002  
metallizzato zinco opaco con fondo /  
mat metallized zinc with primer  
EN028  
nero opaco con fondo / mat black with primer

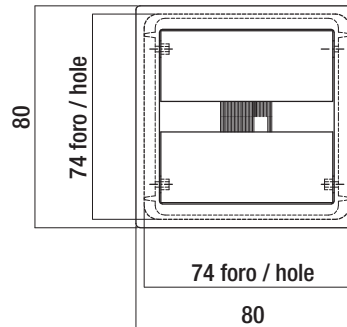

**PC2008I** design Giuseppe Bavuso

**codice / code** PC2008I

**finiture / finishings** EZ002Q102  
metallizzato zinco opaco con fondo con plexiglass /  
mat metallized zinc with primer with plexiglass

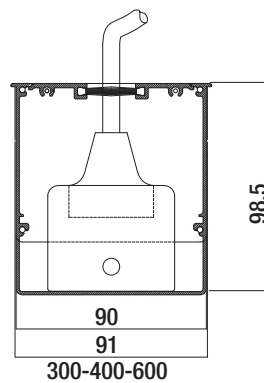

**PC2007I** design Giuseppe Bavuso

**codice / code** PC2007I

**finiture / finishings** EZ002  
metallizzato zinco opaco con fondo /  
mat metallized zinc with primer

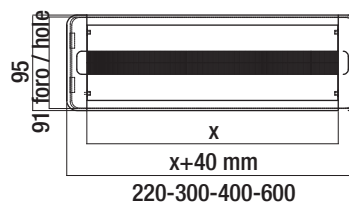

**PC2003I** design Giuseppe Bavuso

**codice / code** PC2003I

**finiture / finishings** EZ002  
metallizzato zinco opaco con fondo /  
mat metallized zinc with primer

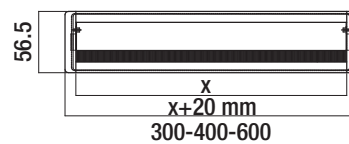

**PC2004I** design Giuseppe Bavuso

**codice / code** PC2004I

**finiture / finishings** EZ002  
metallizzato zinco opaco con fondo /  
mat metallized zinc with primer

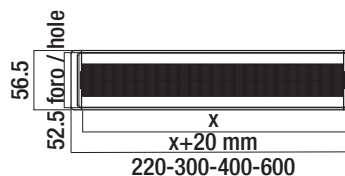

**PC2005I** design Giuseppe Bavuso

**codice / code** PC2005I

**finiture / finishings** EZ002  
metallizzato zinco opaco con fondo /  
mat metallized zinc with primer

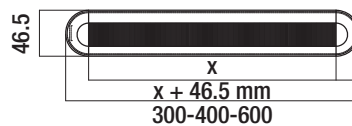



**PC2009I** design Giuseppe Bavuso

**codice / code** PC2009I

**finiture / finishings** EZ002  
metallizzato zinco opaco con fondo /  
mat metallized zinc with primer

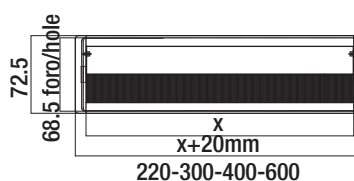

**PC2000Z180** design Giuseppe Bavuso

**codice / code** PC2000Z180

**finiture / finishings** EZ002  
metallizzato zinco opaco con fondo /  
mat metallized zinc with primer  
EN028  
nero opaco con fondo / mat black with primer

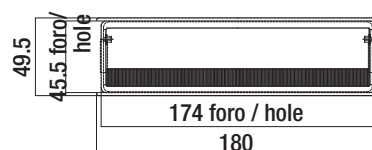

## MN1158Z design Pinuccio Borgonovo



**codice / code** MN1158Z

**finiture / finishings** EA004  
metallizzato alluminio opaco con fondo /  
mat metallized aluminium with primer  
GC011  
cromato lucido / bright chromium plated

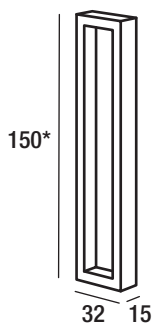

## MN1098Z design Pinuccio Borgonovo



**codice / code** MN1098Z

**finiture / finishings** E215  
metallizzato alluminio opaco con fondo /  
mat metallized aluminium with primer  
G104  
cromato lucido / bright chromium plated

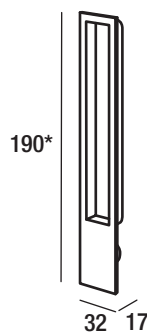

## MN1097Z design Pinuccio Borgonovo



**codice / code** MN1097Z

**finiture / finishings** E215  
metallizzato alluminio opaco con fondo /  
mat metallized aluminium with primer  
G104  
cromato lucido / bright chromium plated

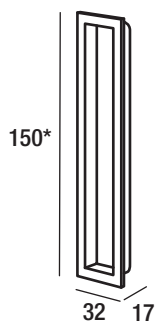

## MN1096Z design Pinuccio Borgonovo



**codice / code** MN1096Z

**finiture / finishings** E215  
metallizzato alluminio opaco con fondo /  
mat metallized aluminium with primer  
G104  
cromato lucido / bright chromium plated

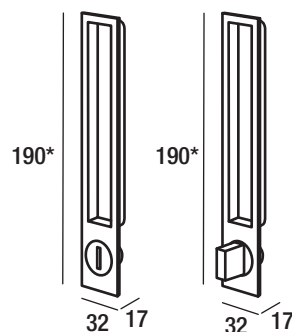

## MN1099Z design Pinuccio Borgonovo



**codice / code** MN1099Z

**finiture / finishings** E215  
metallizzato alluminio opaco con fondo /  
mat metallized aluminium with primer  
G104  
cromato lucido / bright chromium plated

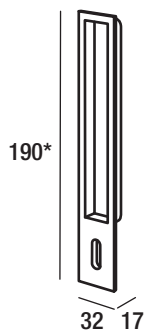

## MN1100Z design Pinuccio Borgonovo



**codice / code** MN1100Z

**finiture / finishings** E215  
metallizzato alluminio opaco con fondo /  
mat metallized aluminium with primer  
G104  
cromato lucido / bright chromium plated

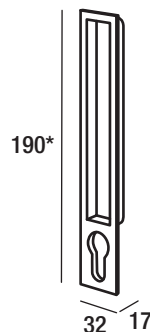



## SHARP design Giuseppe Bavuso

**codice / code** RM013Z

**finiture / finishings** E215  
metallizzato alluminio opaco con fondo /  
mat metallized aluminium with primer  
G104  
cromato lucido / bright chromium plated

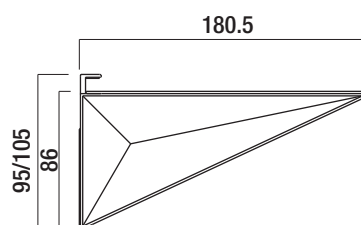

## SLING design Alessandro Elli

**codice / code** RM009Z

**finiture / finishings** E215  
metallizzato alluminio opaco con fondo /  
mat metallized aluminium with primer  
G104  
cromato lucido / bright chromium plated  
G124  
nichel lucido satinato con vernice trasparente /  
bright satin nickel with bright paint

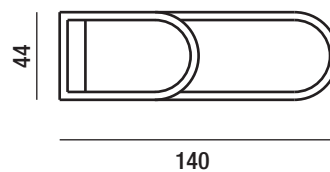



## BLOCK design Marco Zanuso Jr.

**codice / code** RM010X

**finiture / finishings** X103  
acciaio inox lucido / bright inox stainless steel

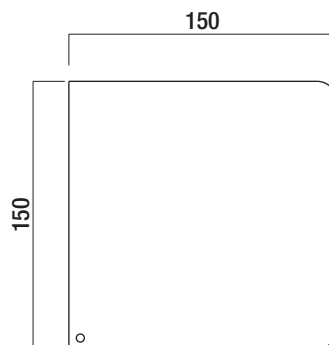

## WEDGE design Giuseppe Bavuso

**codice / code** RM012Z

**finiture / finishings** E215  
metallizzato alluminio opaco con fondo /  
mat metallized aluminium with primer  
G104  
cromato lucido / bright chromium plated  
G124  
nichel lucido satinato con vernice trasparente /  
bright satin nickel with bright paint

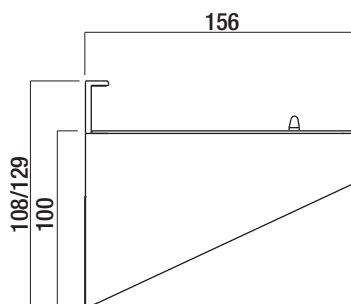

**PU025/5Z** design Giuseppe Bavuso



**codice / code** PU025/5Z  
**finiture / finishings** E101  
metallizzato alluminio opaco / mat metallized aluminium

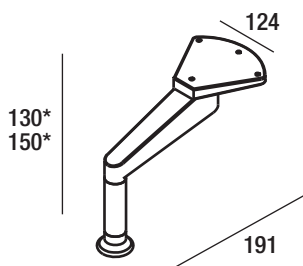

**PU026/1Z** design Giuseppe Bavuso



**codice / code** PU026/1Z  
**finiture / finishings** E101  
metallizzato alluminio opaco / mat metallized aluminium  
G115  
nichel lucido satinato / bright satin nickel

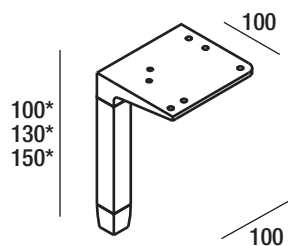

**PG027/2Z** design Giuseppe Bavuso



**codice / code** PG027/2Z

**finiture / finishings** E101  
metallizzato alluminio opaco / mat metallized aluminium  
G115  
nichel lucido satinato / bright satin nickel

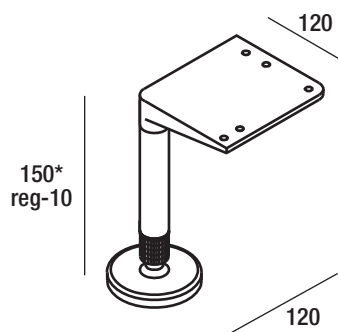

**PU026/3Z** design Giuseppe Bavuso



**codice / code** PU026/3Z

**finiture / finishings** E101  
metallizzato alluminio opaco / mat metallized aluminium  
G115  
nichel lucido satinato / bright satin nickel

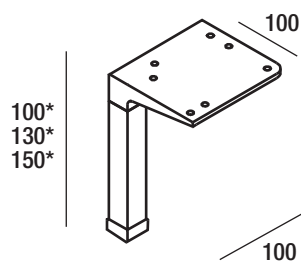

**PA060Z** design Marelli e Molteni



**codice / code** PA060Z  
**finiture / finishings** E101  
metallizzato alluminio opaco / mat metallized aluminium

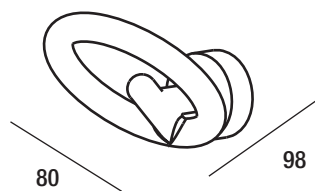

**PA055Z** design CRP



**codice / code** PA055Z  
**finiture / finishings** E101  
metallizzato alluminio opaco / mat metallized aluminium

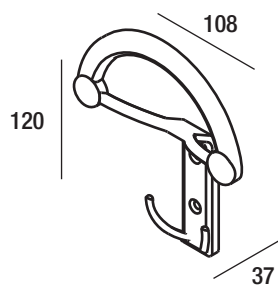

**PA059Z** design Marelli e Molteni



**codice / code** PA059Z  
**finiture / finishings** E101  
alluminio opaco metallizzato / mat metallized aluminium

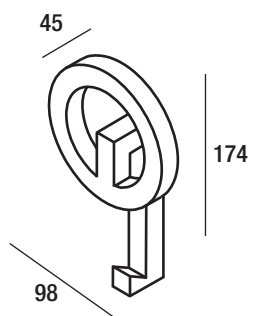

**PA062Z** design Marelli e Molteni



**codice / code** PA062Z  
**finiture / finishings** E101  
metallizzato alluminio opaco / mat metallized aluminium

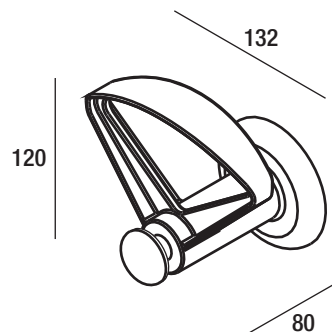

## PA058Z design Marelli e Molteni



**codice / code** PA058Z

**finiture / finishings** E101A190  
metallizzato alluminio opaco + surlyn trasparente texture /  
mat metallized aluminium + surlyn transparent texture  
E101A191  
metallizzato alluminio opaco + surlyn trasparente  
arancio texture /  
mat metallized aluminium + surlyn transparent  
texture orange  
E101A192  
metallizzato alluminio opaco + surlyn trasparente blu texture /  
mat metallized aluminium + surlyn transparent texture blue

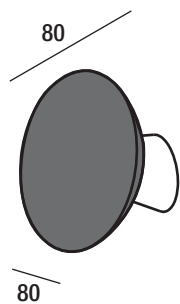





**VR085Z / VR086Z / TL2510** design G. Bavuso



**codice / code** VR085Z / VR086Z / TL2510  
**finiture / finishings** G104  
 cromato lucido / bright chromium plated

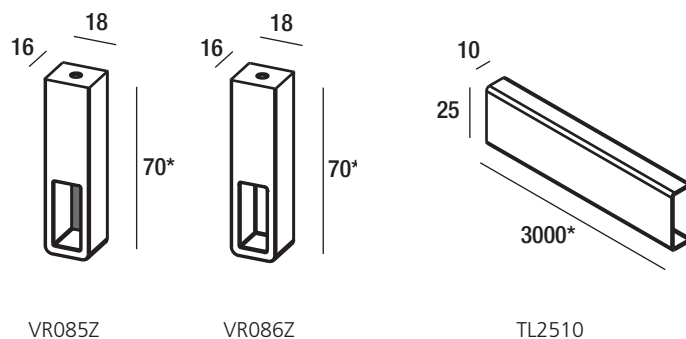

**VR160Z / VR161Z / TJ3012I** design G. Bavuso



**codice / code** VR160Z / VR161Z  
**finiture / finishings** E101  
 metallizzato alluminio opaco / mat metallized aluminium

**codice / code** TJ3012I  
**finiture / finishings** I101O122  
 alluminio anodizzato zero chimico con guarnizione  
 in gomma argento /  
 zero chemical anodized aluminium with silver rubber

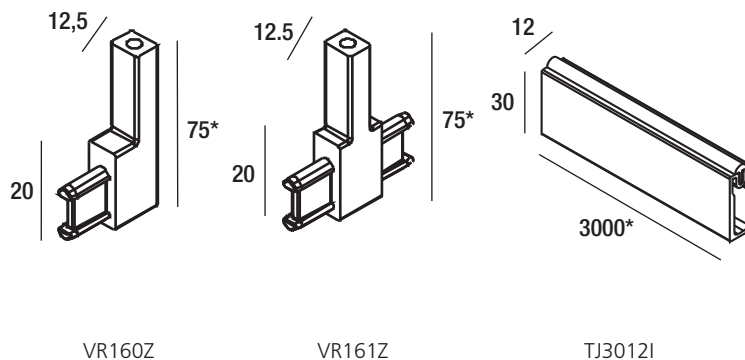

**VR167Z / VR168Z / TJ3012I** design G. Bavuso



**codice / code** VR167Z / VR168Z  
**finiture / finishings** E101  
 metallizzato alluminio opaco / mat metallized aluminium

**codice / code** TJ3012I  
**finiture / finishings** I101O122  
 alluminio anodizzato zero chimico con guarnizione  
 in gomma argento /  
 zero chemical anodized aluminium with silver rubber

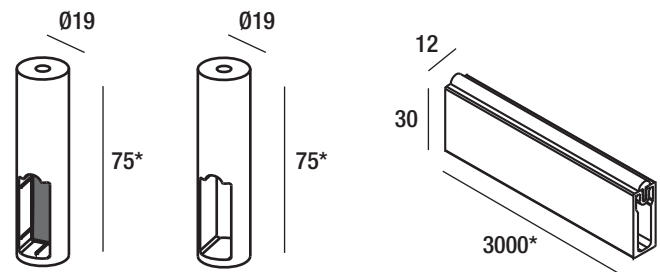

VR167Z

VR168Z

TJ3012I

**VR098Z / VR099Z** design G. Bavuso



**codice / code** VR098Z / VR099Z  
**finiture / finishings** E101  
 metallizzato alluminio opaco / mat metallized aluminium  
 G104  
 cromato lucido / bright chromium plated

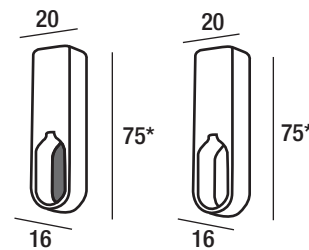

VR098Z

VR099Z

**GA003F** design Giuseppe Bavuso

**codice / code** GA003F

**finiture / finishings** G104A160W0749  
cromato lucido + metacrilato sabbiato opale +  
logo PAMAR argento /  
bright chromium plated + opal sandblasted metacrilato  
+ silver PAMAR logo

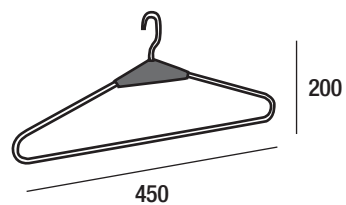



**I modelli Pamar sono protetti da brevetto internazionale.  
La contraffazione sarà perseguita a termine di legge.**

**International patents have been deposited for the Pamar models. Imitations will be punished by law.**

**Die modelle Pamar sind durch internationales Patent geschützt. Fälschungen sind strafbar und werden gesetzmäßig verfolgt.**

**Les modèles Pamar sont couverts par un brevet international. La contrefaçon sera poursuivie aux termes de la loi.**

**Los modelos Pamar están protegidos por patente internacional. La imitación será demandada según las leyes.**

#### **INFORMAZIONI TECNICHE**

- Le misure in bianco sono le dimensioni esterne
- Le misure in rosso sono l'interasse
- Le misure con asterisco \* sono il codice del prodotto
- Le parti in grigio scuro nei disegni indicano applicazioni di differenti finiture

#### **AVVERTENZA**

Pamar SpA si riserva la facoltà di modificare le caratteristiche tecniche degli elementi illustrati nel presente catalogo in qualunque momento che si ritiene necessario. Per ragioni tecniche le tonalità dei colori rappresentati a catalogo possono differire dagli originali.

#### **TECHNICAL INFORMATION**

- White measurements refer to external dimensions
- Red measurements refer to inter-axial hole distance
- Measurements with asterisk \* refer to the article
- The dark grey shading in the drawings possible applications of different materials.

#### **ATTENTION**

Pamar SpA reserves the right to change technical specifications of products illustrated in this catalogue at any time it deems necessary. Colour variations in the catalogue compared with the original colours are possible due to technical reasons

AD **Gordon Guillaumier**  
grafica / graphic **Giuseppe Basile**  
con **Andrea Basile**

foto / photo **Studio BBM**  
**Riccardo Bianchi**  
**Donato Di Bello**  
**Ramak Fazel**

testi / copy **Alam**

impianti e stampa / color separation and print **BSZ, Mazzo di Rho\_Milano**

finito di stampare nel mese di novembre 2010